

CHAPTER 3 SYSTEM DESCRIPTION

The chapter discusses the implementation of automotive power window which consists of DC motor as an actuator, different switches, and sensor as a control input, Control system, mathematical modeling, simulation and validation using HIL testing technique (dSPACE simulator). Then, the objectives of smart power window system for various classes of vehicles during design and development are discussed. Various sources of ambiguity at components level, design level, and fabrication level are also examined and how these uncertainties affect system performance.

3.1 Power Window

System technology in automotive is presently migrating from mechanical domain to electronic oriented domain. This consists of different electromechanical systems like ignition system, injection system, variable valve timing and power windows. These systems must be more user-friendly with respect to customer comfort leading to a new technical requirement for the vehicles. In automotive power window when users give appropriate command then glass frame moves upward and downward automatically. Despite its comfort, automatic control windows bring security issues. For example, the likelihood of harming the body part situated in the way of the window path. As per national highway traffic safety administration report[60], various accidents happen due to lack of safety precaution in power window system. To fulfill functional safety requirement, anti-pinch based power window system [61] caught much attention. Anti-pinch based power window system effectively resolve the security concern and works flawlessly without affecting comfort to the passenger.

Considering another aspect, the differential anti-pinch estimator depends on the presumptions that the sharp decay of speed in the squeeze condition and the glass window move at a consistent speed for smooth working conditions. However, this calculation is reasonably lacking in terms of the fact that the frictional torque acting on the power window system outlines distinctive

attributes. In the anti-pinch estimator algorithm, the amount of calculation required is small. However, the overall performance of the system is degraded because of the existence of different measurement noises in the system. Also, the projected reaction time of absolute anti-pinch algorithm depends on the load current flowing in the DC motor circuit which compensates angular velocity and pinch torque[62] of the system. Conversely, this benefit does not provide assurances that during abnormal vibration under actual driving circumstance provide system robustness. Additionally, anti-pinch estimator algorithm involves extra current sensors to avoid false prediction.

Consequently, such a technique can't be a general arrangement on the grounds that the solution of the anti-pinch condition depends altogether on the specialist's inspiration to decide the present confinements. Past examinations have proposed a sort of calculation that perceives a pinched condition from a distinguished change in the power window speed; another writes about an anti-pinch condition when the connected DC motor torque surpasses a threshold level, requiring an extra current sensor to maintain a strategic distance from the false alert. However, this algorithm cannot consider as a universal solution because of the fact that algorithm depends on prediction and current limit flowing in the load circuit. In the anti-pinch algorithm, pinching condition is identified due to change in motor current and accordingly pinch torque, power window velocity and low response time are discussed.

Model-based development has established abundant consideration in current years, particularly in the design and development of the electromechanical based system comprises electrical and mechanical actuators and pinch detection mechanism[63]. The embedded development board process driver controlled and passenger controlled inputs for upward and downward movement. When the upward switch is pressed either driver controlled or passenger controlled power window will move forward direction and vice versa. With the help of MOSFET based H bridge circuit makes DC Motor move anticlockwise to the clockwise direction and vice versa when the appropriate switch of H bridge circuit got energized. In above case, two

closeness sensors are utilized first on the top side of the frame and second on the bottom side of the car window frame. The exact location of glass window frame is identified by the two closeness sensor. In this investigations, multiple sensory data are utilized are current, flexi force and temperature data.

Every segment of automobile uses power window systems and to successful implementation of the vehicle requires functional safety and standard working principle to ease of preventing fatal accidents. Pet neck trap, human body, child's hands are few instance categories under fatal accidents in power window system. These instances lead to obstruction due to fault in the power window system development.

3.2 Linear Motor Model

The most common actuator used as an electrical device in the mechanical control system is the DC motor. For power window system, the control of a cross arm mechanism requires a DC motor to drive the pinion gear which is coupled on the rotor shaft and cross arm mechanism consists of ring gear through which glass window frame[64] is moving upward and downward direction shown in Figure 1-2. With help of gear arrangement and cross arm mechanism of power window system, DC motor provides rotary motion into translational motion. The electrical circuit of the DC motor consists of the armature winding and field winding represented in Figure 3-1. The information required for the physical model of power window framework[65] is the voltage connected to the DC motor armature loop, while the yield is the rotational development of the rotor shaft (RPM).

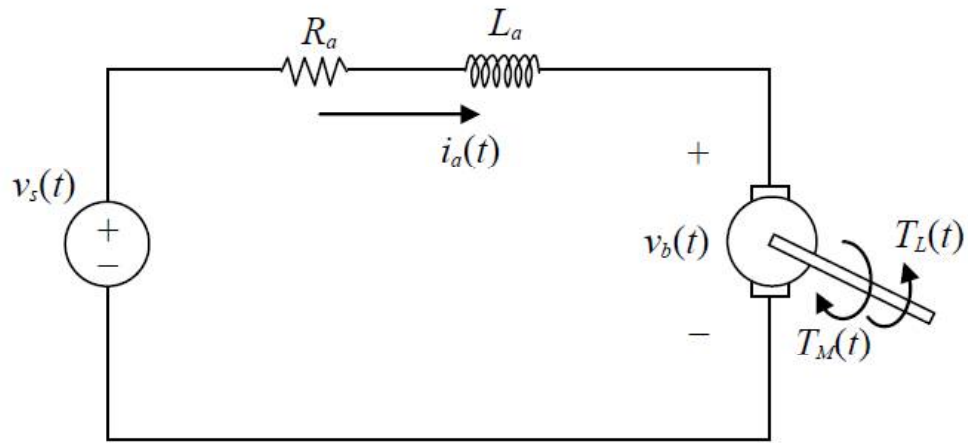

Figure 3-1 physical model circuit diagram of power window system

The power window system structure which consists of a DC motor and gear arrangement[66, 67] is depicted in Figure 3-1, includes armature resistance R_a , Armature current is represented as $i_a(t)$, $v_b(t)$ is the back emf voltage, similarly source voltage is represented as $v_s(t)$ and winding leakage inductance L_a .

DC motor electrical equation is derived from Kirchhoff's voltage law which is represented as

$$R_a i_a(t) + L_a \frac{di_a(t)}{dt} + v_b(t) = v_s(t) \quad (3-1)$$

Where $v_b(t)$ is back emf voltage which is proportional to the angular velocity $\omega(t)$, expressed as

$$v_b(t) = k_b \omega(t) \quad (3-2)$$

Where back emf constant is represented as k_b . The motor generates a torque T_M which is equal to the armature current, specified as

$$T_M(t) = k_T i_a(t) \quad (3-3)$$

Where k_T is the torque constant. If the input voltage $v_s(t) = V_s$ is a constant parameters then the resulted armature current is $i_a(t) = I_a$, and if angular

velocity $\omega(t) = \omega$ and torque $T_M(t) = T$ which is again a constant parameters during steady state analysis. From equation (3-1) and (3-3)

$$R_a I_a + k_b \omega = V_s \quad (3-4)$$

$$T = k_T I_a \quad (3-5)$$

Consider the law of conservation of power, we know that the input power is equal to output power whereas input power i.e. $I_a V_s$ is equal to the output power or shaft power of the DC motor i.e. $T\omega$ and the input power for DC motor is $R_a I_a^2$.

$$V_s I_a = T\omega + R_a I_a^2 \quad (3-6)$$

Considering equation (3-4) and (3-6) yields

$$T = k_b I_a \quad (3-7)$$

From (3-5) and (3-7), we know that both torque parameters k_T and k_b remains same so $k_T = k_b = k$. From (3-2), we can rewrite (3-1) and (3-3) as

$$R_a i_a(t) + L_a \frac{di_a(t)}{dt} + k\omega(t) = v_s(t) \quad (3-8)$$

$$T_M(t) = k i_a(t) \quad (3-9)$$

Assume, power window DC motor is going to drive an external torque $T_L(t)$ which is coupled with cross arm mechanism of power window system then the mechanical behavior[68] of system with payload is described as

$$J_M \frac{d\omega(t)}{dt} + B_M \omega(t) = T_M(t) - T_L(t) \quad (3-10)$$

Where J_M , B_M is the coefficient of moment of inertia and coefficient of frictional force.

Based on equation (3-8), (3-9) and (3-10), the overall equation of DC motor which exhibits dynamic characteristics can be represented as

$$L_a \frac{di_a(t)}{dt} + R_a i_a(t) + k\omega(t) = v_s(t) \quad (3-11)$$

$$J_M \frac{d\omega(t)}{dt} + B_M \omega(t) - k i_a(t) = T_M(t) - T_L(t) \quad (3-12)$$

From motor characteristics, we know that the L_a/R_a is the electrical time constant exhibits very small magnitude. Whereas J_M/B_M is the mechanical time constant of significant value. If we compare both time constant then the electrical time constant is neglected since it is one order less in magnitude. In other words, dividing equation (3-11) by R_a both on RHS and LHS and neglecting the term $\frac{di_a(t)}{dt}$ leads to

$$i_a(t) = \frac{1}{R_a} v_s(t) - \frac{k}{R_a} \omega(t) \quad (3-13)$$

Substituting equation (2-13) in equation (2-12) becomes

$$\frac{d\omega(t)}{dt} + \left(\frac{B_M}{J_M} + \frac{k^2}{J_M R_a} \right) \omega(t) = -\frac{1}{J_M} T_L(t) + \frac{k}{J_M R_a} v_s(t) \quad (3-14)$$

From equation (3-14) Noticeably, the DC motor characteristics equation depend on two external sources, one is input voltage $v_s(t)$ to drive the power window DC motor and the second input is torque $T_L(t)$ acted from cross arm mechanism of power window system[69] as a payload. The linear model of DC motor is represented in Figure 3-2. The input to the linearized DC motor is w and u which is represented as angular velocity and the driving voltage.

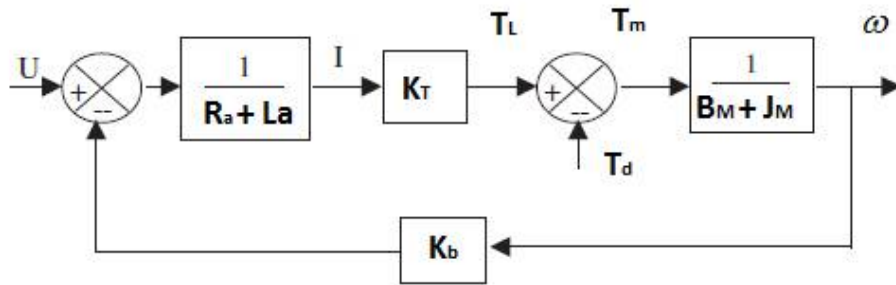

Figure 3-2 Linear power window DC motor model

3.3 Gear Train Model

In this section modest kinematic models of mechanical arrangement among power window DC motor and the mechanical arrangement using gear train of cross arm based power window system analyzed. DC motors are configured with running mechanisms of power window via rotor shafts which is part of mechanical power transmissions called cross arm mechanism. As per different classification[70] of vehicles like SUV, MUV, Passenger car, Commercial vehicle etc. have different shafts lengths of the rotor and their cross-sectional area. Through gear train and clutches mechanism power is transmitted to vehicle door glass frame.

Rigid transmission system with non-zero mass is one classification related to power window mechanism. The mass of DC motor rotor shaft also called transmission rod is scattered constantly along the longitudinal[70] arrangement of the section. The DC motor rotor transmission system with non-zero mass is represented in Figure 3-3, where the genuine interfacing component with constant mass conveyance has been substituted by the association including two weightless components speaking to its longitudinal measurement and one component speaking to its mass.

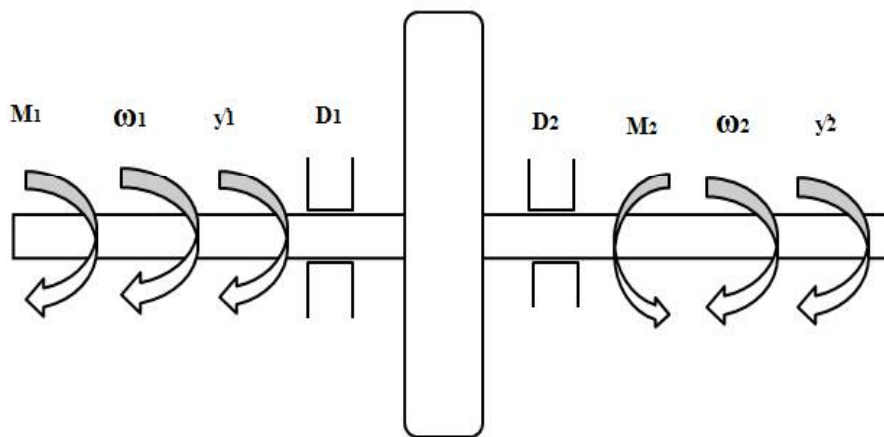

Figure 3-3 Rigid transmission shaft model with non-zero mass

The corresponding similar circuit of a kinematic model of rigid transmission system with non-zero mass is shown in Figure 3-4, where J is a moment of inertia acting on DC motor shaft.

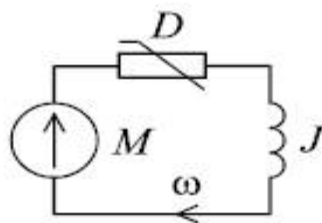

Figure 3-4 Circuit diagram of the transmission shaft

From Figure 3-4 it is observed that it is a circuit consist of mass, damper and moment of inertia. Behalf of equivalent circuit equation (3-15) may be written using analogy principle. In the analogy principle[71] applied to above circuit represents voltage source followed by two components resistance and inductance.

$$M - D\omega - \frac{d}{dt}(J\omega) = 0 \quad (3-15)$$

Where $\frac{d}{dt}(J\omega)$ is dynamic torque of the system, J is Rotor moment of inertia, M_1 & M_2 are the two masses of the system where both sides of shaft external torque is applied, ω_1, y_1 and ω_2, y_2 are angular velocities and angles of rotation, D_1 and D_2 are mechanical friction coefficients defined for bearings.

3.4 Control System

From ancient years of civilization control systems technique exist in human society. The progression of the control system has played a leading role in the transformation of modern civilization. Control systems find vast applications which are not only limited to the industry but every aspect of modern living from regular home usage to complex aircraft. The current chapters deal with two control techniques one for motor control and another for power window control system[72]. The current research looks forward to improving a key

aspect of closed loop based power window control system. The algorithm used for pinch detection techniques uses decision tree classifier approach which is discussed in the subsequent chapter.

Control system frameworks are utilized fundamentally for basic decision making capability i.e. giving self-governance to a complex electromechanical system with the dynamic framework. In power window control system manages glass frame upward and downward movement commands DC motor to rotate clockwise or counterclockwise, directs valid input to pinch detection algorithm and regulates the behavior of automatic power window[73] devices using open loop control techniques and closed-loop control techniques. In open loop control system output has no impact on control action. If the user gives input signal to the driver circuit then power window DC motor will rotate clockwise or counter clockwise direction shown in Figure 3-5.

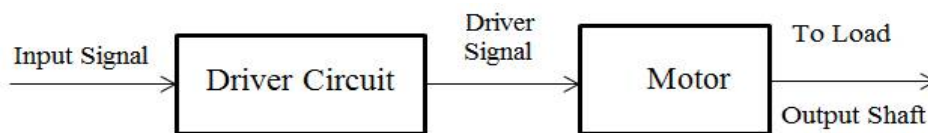

Figure 3-5 Open loop Control System

A system which has one forward path and one or multiple feedback path between input and output which is categorized[74] under closed loop control system. A feedback controller compares the reference set-point with the measured value of the controlled parameter in order to calculate the error which is a deviation from the desired value and takes the control action to eliminate the error. The feedback system basically states that some portion of the output is returned back to the input to form part of the excitation of the system shown in Figure 3-6.

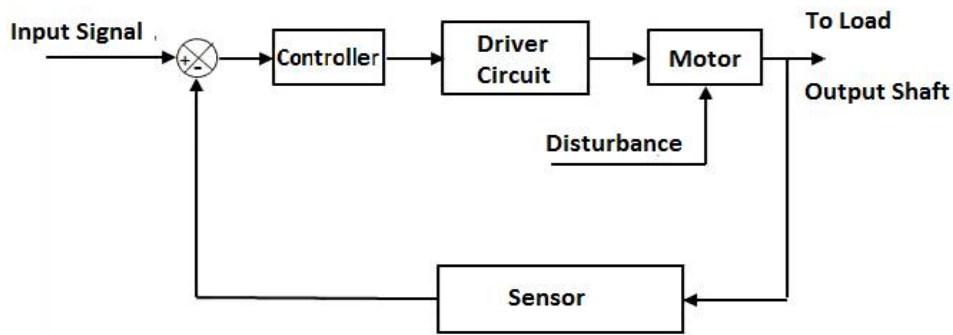

Figure 3-6 Closed loop control system

In the case of closed loop power window linear systems, a control loop includes various sensors like current sensor, flexi force sensor, decision tree classifier as control algorithms, and MOSFET based H Bridge to drive DC motor which is an actuator is arranged to move cross arm mechanism based power window shown in Figure 3-7.

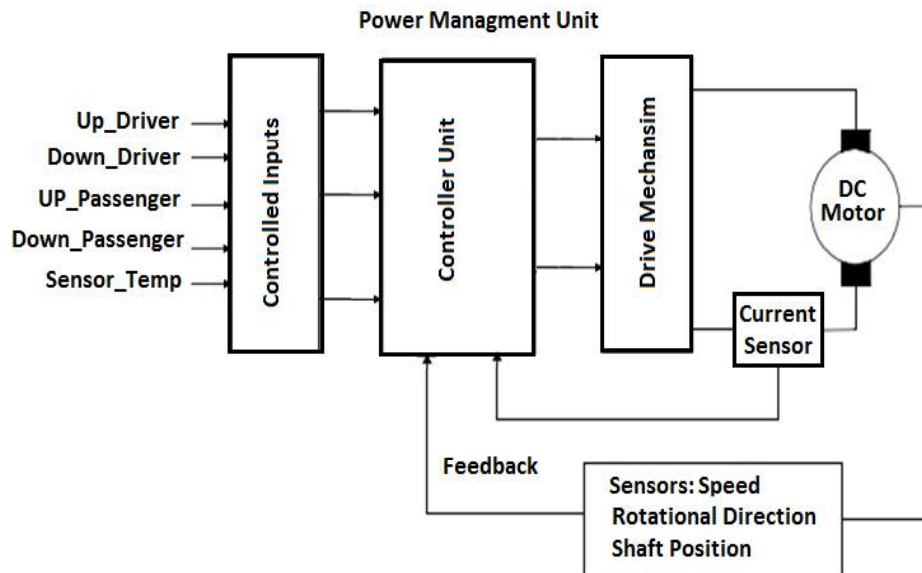

Figure 3-7 Feedback based power window system

3.5 Hardware in Loop (HIL) Simulation

In this section hardware in loop simulation technique, its configuration with the host system and different I/O configuration is discussed.

3.5.1 Introduction

Electrical drives are progressively utilized as a part of the automobile industry. Before implementing on the actual system during development cycle rigorous performance characteristics[75] assessment has to be made in the early stage itself. Thorough execution assessment must be made amid hardware advancement and before usage on the actual hardware system. Specifically, connections of the drive circuit with the movement part (DC motor) must be examined altogether. For the whole electromechanical system, computer simulation plays a vital role to investigate communication between different subsystems to establish technical requirements.

Hardware- In- the- Loop (HIL) simulation became popular from last decade which an advanced tool to investigate experimental setup, system model validation, and testing drivers before implementation of the real processes. With advancement in technology only simulation model is not appropriate to understand system behavior and its characteristics so Hardware- In- the- Loop (HIL) simulation replaces computer simulation techniques and incorporates different hardware like sensors, actuators and drive circuit shown in Figure 3-8. With acceptable input-output competence, the physical system and control processes are simulated in a real-time environment. To achieve this real-time computation process[76] typically requires a parallel computing environment.



Figure 3-8 dSPACE internal system

In the recent year's configuration of hardware components with HIL simulators requires power electronics based different driver's circuit which is high bandwidth and power amplifier equipment. Because of the adaptability of Hardware-In-the-Loop (HIL) simulation tool through which reproductions to test[77] an extensive variety of working conditions and situations this technique will add to enhancing the accessibility and dependability of drives (machines, control hardware, as well as control system techniques) and a superior comprehension of framework connections before their implementation on the physical system.

Hardware-In-the-Loop (HIL) simulation and interfacing with physical component have been popularly implemented and validated for controller design and assessment from a long time. Considering safety critical system like flight control, power management etc. in avionics industry extensively using HIL simulator. The methodology adopted in HIL simulation covers comprehensive[78] testing of the control system that prevents usage of costly and damageable equipment. However, Hardware-In-the-Loop (HIL) simulation using dSPACE kit decrease development cycle time.

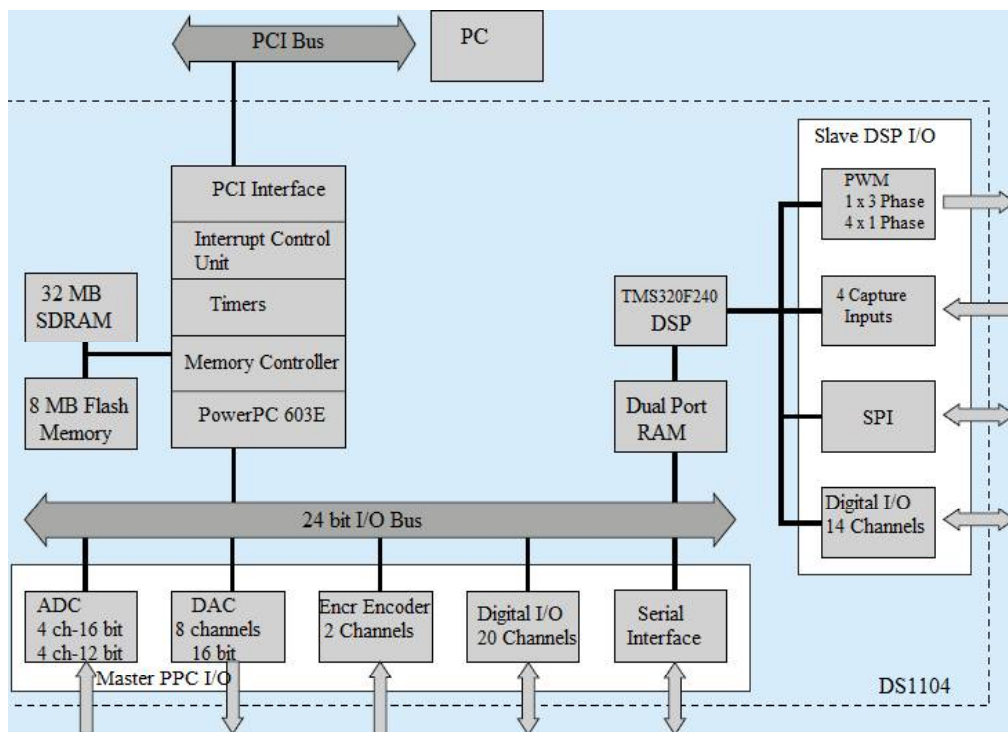

Figure 3-9 Block diagram of dSPACE Ace 1104 with multiple inputs

3. 5. 2 System Description

The electromechanical model presents the DC motor coupled power window system. The power window mechanism is driven through the DC motor with a self-locking mechanism having ring and pinion gear with gear ratio of 1: 50. Lead screw having pitch length of 3 mm is coupled with ring gear to generate linear movement of power window system. The mechanism used in electromechanical power window system required pulley for driving arrangement called as driving pulley “DP” followed by four supportive rollers RL1, RL2, RL3 and RL4 which is integral components of cross arm mechanism, apart from that system have two additional glass claps represented as GCL1 and GCL2. When DC motor rotates in clockwise or counter clock wise direction then accordingly glass claps moves upward or downward and subsequently power window moves in appropriate direction[79]. In cross arm mechanism glass claps GCL1 and GCL2 rotates which is further attached through rope arrangement and accordingly both claps GCL 1 and GCL2 rotates at identical speed maintaining a level of glass window movement symmetrical.

During development of simulation model using MATLAB/Simulink, rope drum block, supporting rollers and belt drive pulley block form the electromechanical power window system. The driving pulley is simulated with Simulink using the Rope Drum block, while the supporting rollers (RL1, RL2, RL3, and RL4) are modeled with Belt Drive Pulley blocks (DP). Description and specification of the various mechanical components used in the development of plat model using Simulink are captured in Table 3-1. The controller must decide the behavioral characteristics for power window development based on various information esteems and indicated framework necessities. With help of various input like driver upward, passenger upward, driver downward and passenger downward switch, similarly sensory data like current sensor, flexi force sensor, and temperature sensor are used as

controller input through which upward and downward[80] movement of power window system achieved.

Driver upward, passenger upward, driver downward and passenger downward are digital I/O switch[81] whereas current sensor, a flexi force sensor, and temperature sensor are an analog sensor which is configured with ADC port.

Table 3-1 Physical parameters for simulation model

Sr. No	Specification	Constant Value
1.	Moment of inertia of Rotor	$3.2284 \times 10^{-6} \text{ kg.m}^2$
2.	Friction constant (Viscous) of motor	$3.5077 \times 10^{-6} \text{ Nms}$
3.	Forcing constant (EMF)	0.0274 V/rad/sec
4.	Torque constant of DC Motor	0.0274 Nm/Amp
5.	Resistance (R)	4 Ω
6.	Inductance (L)	$2.75 \times 10^{-6} \text{ H}$
7.	Rotor Damping Content	1×10^{-6}

3. 5. 3 Implementation of Model with Real-Time Interface (RTI)

1. Model Design with Simulink

In the power window system and block diagram representation shown in Figure 3-7 explains the closed control loop of the power window system for the automotive application.

2. Simulation with Matlab/Simulink

Different signal generator block taken from Simulink platform produces multiple signals which represent switch or sensory condition, although output response is represented through scopes which display system characteristics.

3. Input/Output Configuration

After finishing simulation model in Simulink, research needs to develop the configuration and implementation of plant model hardware. The plant model input signals are substituted by Input-output blocks, and it develops real controlled system environment.

4. Parameter Description

Different Input and output configuration are quantified by selecting I/O block in RTI library if the input is switch then digital I/O must be configured similarly if the input is analog signal then A/D block is selected from RTI library. Sensor data is captured through ADC block and analog output through DAC is given to physical model.

5. Implementation on dSPACE Hardware.

Automatic implementation of the Simulink model on dSPACE hardware is the key to rapid design iterations. With RTI, during experimentation user is not able to see a single line of code during this process. A single click on the Build button starts the implementation, which includes code generation, compiling, and downloading. During the investigation, user can select an integration algorithm and a step size in the solver page of the simulation parameters dialog. Build procedures can also be automated with the help of scripts. This is especially helpful for large models[82].

6. Communication with Physical model

At the point when the application model is running on the physical equipment, the whole dSPACE simulator is available for the system development. Real-time interface tool ensures complete control over different variable used in the system implementation process. With help of control desk [83] various measuring instruments data virtually available on the control panel where the user can monitor the data and change the parameters as per need without redevelopment of the code. Any variable history in terms of input-output characteristics is available on a virtual panel called control desk.

3.6 Test Bench System

The project setup also called “Power window test bench system” is portrayed in Figure 3-10. The extremely vibrant automotive power window physical model system consists of a DC motor mechanism coupled with the gear train forms window lifting mechanism. The system is coupled with dynamometer which controlled through power electronics drive circuit. In addition to that system requires control input[84] in term of the downward and upward switch for the power window, different control through dynamometer to obtain measurement data in terms of Current, Torque and rotor shaft speed. In dSPACE simulator system entire process is validated with different input-output card analog to digital converter (ADC), Digital to analog converter (DAC) and multiple I/O port.

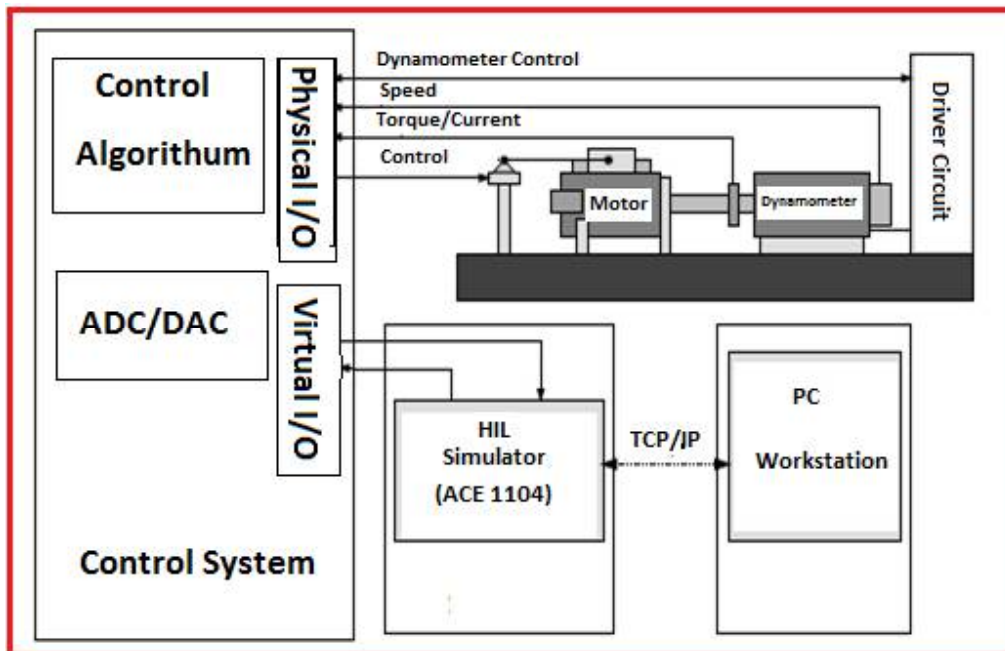

Figure 3-10 Power window test bench system

Design and development of power window system for different testing techniques are represented in Figure 3-11 for fatigue testing of a different condition of DC motors used for moving glass frame upward and downward.

- A PC based system with dSPACE and Matlab/Simulink software for data acquisition and control desk for the interactive user interface.
- All the four-door of a vehicle which is part of power window system uses DC motor has to test for various performance characteristics and it is closely monitored for multiple cycles.
- Current being drawn by motors during upward and downward movements which are monitored as per permissible set limits.
- Power window upward and downward movement speed is closely monitored for multiple cycles.
- Performance analysis of power window system various parameters data logging being done for system behaviors.



Figure 3-11 Test Bench setup of power window system with dSPACE Kit.

The chapter concludes system design which covers power window system, linear motor model, gear train model, controls system for motor and power window, hardware in loop simulation with dSPACE simulator, test bench setup of power window system with ACE 1104 hardware kit. The next chapters of the report extend this implementation and validate power window application on the hardware.